

# CX<sup>3</sup> changeover switches, push-buttons, control switches and LED indicators

## technical characteristics

### ■ Dimensions

#### Changeover switches

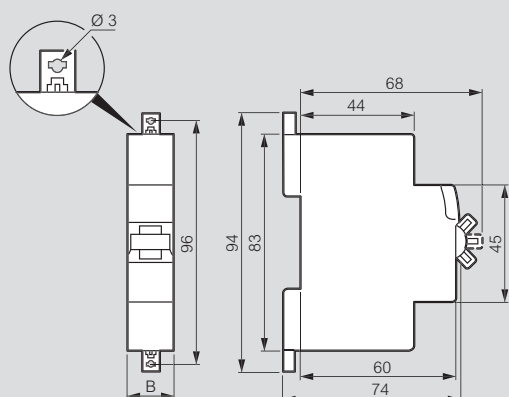

Cat.Nos	B
4 129 00/02/04	17,7
4 129 01/03	35,6

### ■ Technical characteristics

#### Changeover switches

Power dissipation per pole : 1.5 W  
 Overvoltage category : 4 kV $\sim$   
 Dielectric withstand : 2 kV $\sim$   
 Degree of pollution : 2

#### Push-buttons and control switches

Electrical endurance : 30 000 cycles AC12  
 ( $\cos \varphi = 0,9$ ) IEC 60947-5-1  
 Electrical endurance under fluorescent loads : 30 000 cycles according to IEC 60669-1

#### LED indicators

Equipped with non replaceable LED lamps  
 LED life : 100 000 h.  
 LED consumption :  
 - 0.17 W under 230 V $\sim$   
 - 0.11 W under 24 V $\sim$

#### Push-buttons and control switches

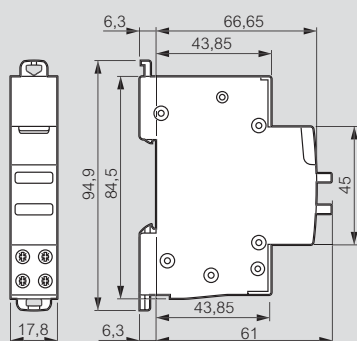

#### LED indicators

